

# AG-900+ Modular Dispensing Applicator

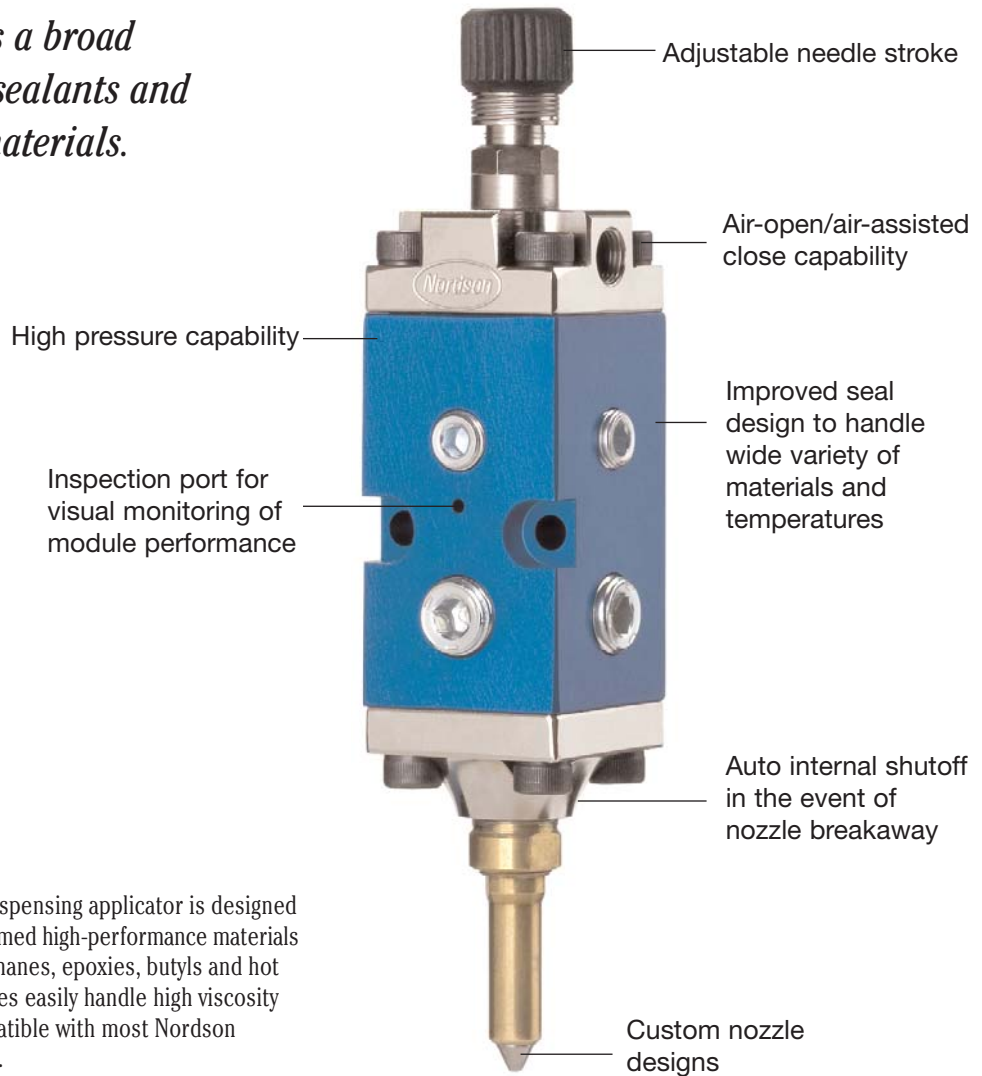

*Accurately dispenses a broad range of adhesives, sealants and high performance materials.*



The Nordson AG-900+ modular dispensing applicator is designed for the application of solid and foamed high-performance materials such as silicones, plastisols, urethanes, epoxies, butyls and hot melts. Large internal fluid passages easily handle high viscosity materials. The applicator is compatible with most Nordson automated dispensing equipment.

The modular design of the AG-900+ dispensing applicator allows different assembly for various gasketing, sealing and bonding applications. The applicator module can be used independently or with combinations of regulators, actuators and hose interfaces.

The AG-900+ module allows for standard or custom nozzle and needle designs to meet a variety of product application requirements. A zero-cavity feature of the dispensing head is available and provides accurate material flow and positive shutoff to help eliminate clogs or dripping.

The AG-900+ dispense head can incorporate an optional pressure regulator attached to the module. The pressure regulator reduces pressure fluctuations, particularly during opening. This allows the output of the applicator to be maintained at a consistent rate.

## Features and Benefits

- Modular design allows configuration for a variety of dispensing functions.
- Zero-cavity feature available for positive material shutoff.
- Optional dispense-head regulator provides accurate dispense control by regulating pressure in the nozzle.
- Hose interface options reduce stress on hoses and robots in automated applications.
- Compact size and weight allow use in most production environments.
- Improved overall design to reduce cost of operation and maintenance.

# AG-900+ Modular Dispensing Applicator

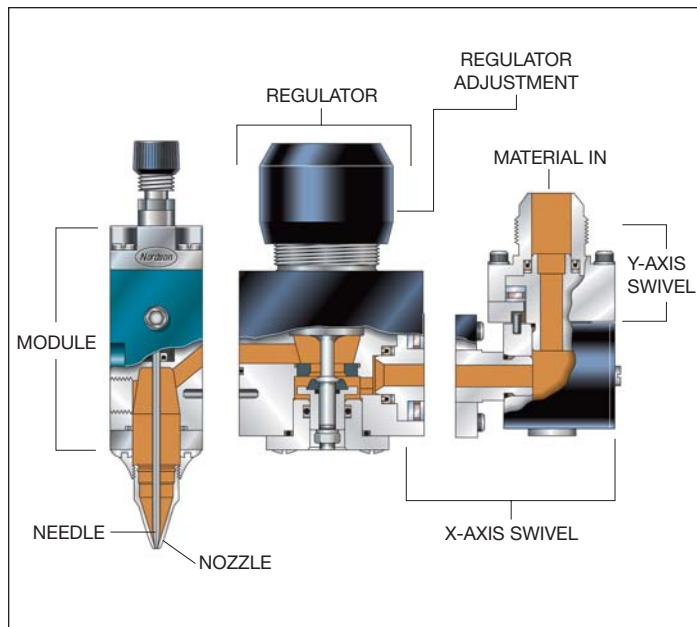
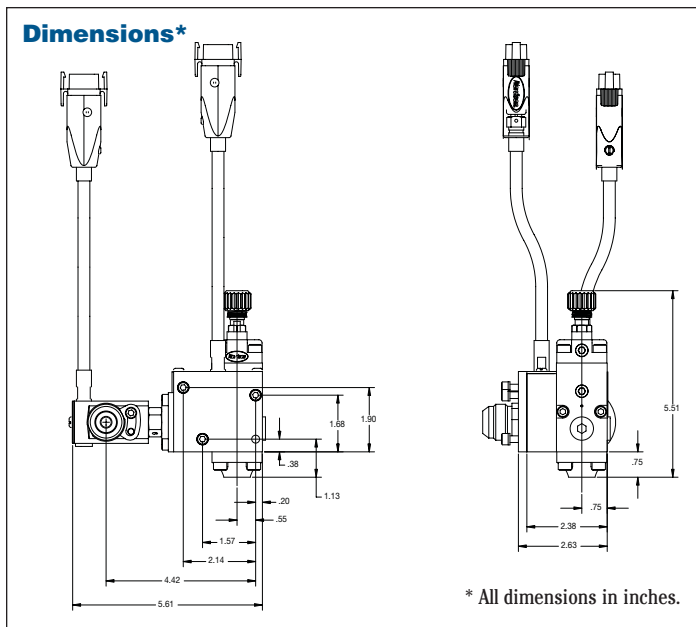

AG-900+ dispensing applicator in window backbedding application

## Technical Specifications

<b>Operating Temperature (max.)</b>	400° F (204° C)
<b>Maximum Input Pressure</b>	3,000 psi at 250° F (20,684 Kpa at 121° C) 1,500 psi above 250° F (10,342 Kpa above 121° C)
<b>Electrical Requirements</b>	
<b>Heated Applicator</b>	200/240 VAC, 50/60 Hz 270 watts – module/regulator 100 watts – swivel
<b>Operating Air Pressure</b>	60-100 psi (414-689 Kpa)
<b>Operating Speed (max.)</b>	3,200 cycles/minute
<b>Material Viscosity Range</b>	1,000-1,000,000 cps



For more information, talk with your Nordson representative or contact your Nordson regional office.

<b>United States</b> Duluth, Georgia Telephone: (800) 683-2314 Toll-free Facsimile: (866) 667-3329	<b>Canada</b> Markham, Ontario Telephone: (800) 463-3200 Facsimile: (905) 475-8821	<b>Europe</b> Lüneburg, Germany Telephone: (49) 4131-894-0 Facsimile: (49) 4131-894-149	<b>Japan</b> Tokyo, Japan Telephone: (81) 3-5762-2700 Facsimile: (81) 3-5762-2701	<b>Asia/Australia/ Latin America</b> Amherst, Ohio Telephone: (440) 985-4797 Facsimile: (440) 985-1096
--	---	--	--	---

[www.nordson.com](http://www.nordson.com)



When you expect more.®